



UNDERGROUND SERVICE

GENERAL REQUIREMENTS

If you wish to have an underground service to your home, the information in this chapter will help you.

The following is a checklist, which should be used as a guide to assist you in preparing your project for the installation of your underground service. Once you have completed these items, CLPUD will install your service line and meter.

- Ask us where your service line will originate. Call your nearest service office and ask to speak to an engineer (see page 21).
- Determine an acceptable location for your meter base (see page 5).
- Dig a trench and provide conduit from your meter base to the service hand-hole location, then to the location where your service will originate.
- Install CLPUD provided service hand-hole (HH-14 or HH-20), and CLPUD provided pull string.
- Install your service equipment.
- Have the local electrical inspection agency (see Page 4) approve your service installation.
- Call CLPUD's service office and notify them that you are inspected and have a "green tag" sticker on your meter base.

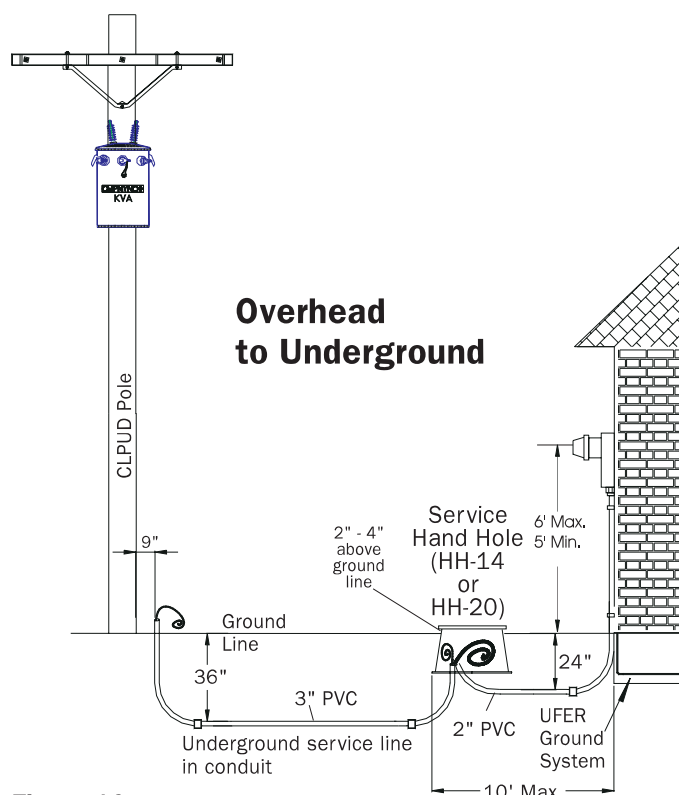

Figure 16.
Typical overhead to underground service.

GETTING STARTED

The first step when installing a new underground service is to contact our nearest service office and ask an engineering technician where your service will originate.

Next, determine the location of your meter base. As stated previously, your meter base should be located outside and on the front, or within 4 feet of it on the side closest to normal public access (see page 4).

When choosing your meter base location, be sure to consider the types of terrain where your conduit will be buried. You are required to provide and install conduit, and CLPUD is responsible for repairing service line if it ever fails. You must use 3" inch Schedule 40 PVC electrical grade conduit unless dictated by other ordinances and approved by CLPUD. You will also need a service hand-hole.

Customer-installed continuous conduit runs shall not contain more than 180 degrees of long radius bends, unless pre-approved by an engineering technician.

Conduit runs of more than 50 feet, or containing more than two 90 degree PVC elbows shall have a CLPUD-provided pullstring installed.

SERVICE EQUIPMENT INSTALLATION REQUIREMENTS

After you have determined the meter base location, the service line route, the size of the service you want (200 or 400 amp), you are ready to begin installing your service equipment.

There are three ways this equipment can be installed:

Flush mounted (See Figure 19)

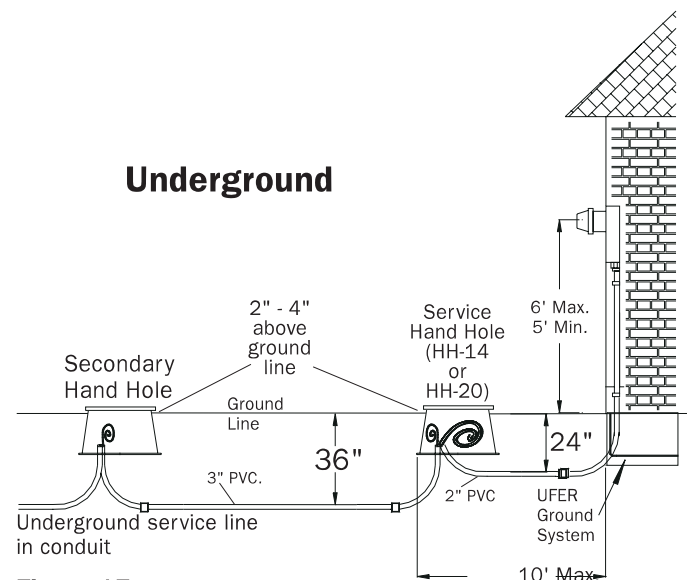

Figure 17.
Typical underground service.

Surface mounted (see Figure 20)

Pedestal mounted (see Figures 21 & 22, page 16)

When installing your service equipment, make sure that you install your meter base so that the center of the meter will be between 5 and 6 feet above finished grade.

TRENCHING REQUIREMENTS

You are to provide a trench, 24 inches deep from your meter base to the service hand-hole (HH14 or HH20). Your trench will then continue, at 36 inches deep, to the pole, transformer, or secondary hand-hole where your service will originate. The trench must have a level, flat bottom, void of shifting soil. The trench must be free of all sharp rock and construction debris. There must be at least 12 inches of separation from all other utilities within the trench (see Figure 18). The trench must be a minimum of 3 feet from sewer and gas, and 5 feet from septic tanks and 10 feet from any drain fields.

When trenching to a transformer, don't use any digging equipment other than a hand shovel within 5 feet of transformer. Remember, **do not dig under the transformer**.

Also remember:

Call before you dig: **1-800-332-2344** (see page 4).

CONDUIT

Customer will provide conduit and conduit elbows from the meter base to the service hand-hole (generally 2" - see NEC). Continue with a second set of 3" conduit and conduit elbows from the service hand-hole to the CLPUD source (pole, transformer or secondary hand-hole). The conduit will be Schedule 40 PVC electrical grade unless otherwise required by the engineering technician, road right-of-way administrator, or electrical inspector (see Figures 16 & 17).

You are required to keep the conduit clean and clear of debris and water. End plugs will be provided by CLPUD, and you are required to have these installed.

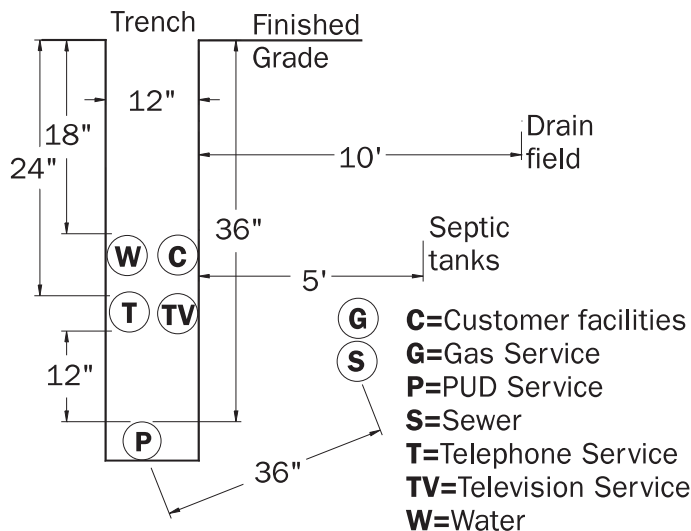

Figure 18.
Service line trench detail.

Do not install conduit into energized equipment such as a transformer or an energized hand-hole.

At a transformer, or energized hand-hole location you will need to call our service office to coordinate our being at the site to assist you in installing the elbow, pullstring and backfill.

You will need to install all conduit, pullstring, service hand-hole, trenching and backfill from the meter base to the CLPUD source (pole, transformer, secondary hand-hole).

SERVICE HAND-HOLE

You'll need to pick up and transport a service hand-hole from CLPUD to your site. (Ask engineering technician for details.) If your service is a 200 amp single meter base installation you can pick up the HH14 at your local service office.

If you have a bigger meter base, or more than one meter, you'll need to pick up a larger service hand-hole from your local CLPUD warehouse. Ask your engineering technician for warehouse location and hours of service.

It is your responsibility to install the service hand-hole in your trench (see Figures 16, 17 and 18), within 10 feet of the meter base. The lid portion of the service hand-hole must be above the finished grade.

Two conduit elbows are required inside the service hand-hole (1 from the meter and 1 from the pole, transformer or secondary hand-hole). The two elbows are to be 2" above the bottom of the dirt floor of the hand-hole, and centered in the short side of the hand-hole (see the Top View in Figures 19 and 20).

Do not install the service hand-hole in a concrete area unless you receive prior instruction from an engineering technician. If the service hand-hole fills with water, you are required to provide adequate drainage, possibly excavating a larger area and underlying the service hand-hole with gravel.

PULLSTRING

Your engineering technician will provide you with pullstring if your trench is over 50 feet long or has more than 180 degrees in elbows. It is to be blown in after the sections of the conduit have been glued and the glue has properly dried.

BACKFILL

After you have installed the trench, conduit, service hand-hole and pullstring, you're ready to call your service office for a trench inspection. You may use the original trench material for backfill, after the inspection, if it is clean (does not contain rock, construction debris, etc). Otherwise, sand is the preferred backfill.

TRENCH INSPECTION

All CLPUD underground box and duct systems done by customers, contractors or builders will require a final inspection and approval by a CLPUD Operations Department

inspector. The CLPUD inspector must approve all jobs requiring trenching before the CLPUD service or line crew can be dispatched to do the electrical installation (see Page 23).

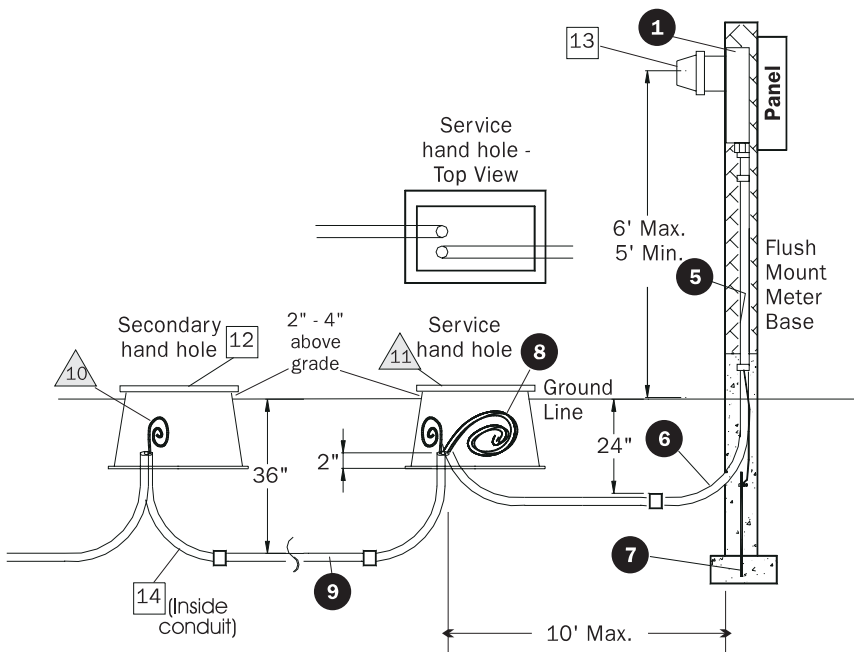

Figure 19.
Flush-mounted meter base with CLPUD secondary hand hole.

● Items owned and installed by customer

(Figs. 19 & 20)

1. Meter base.
2. Insulating bushing and lock nut.
3. Terminal adapter.
4. Conduit strap.
5. Service entrance conduit as specified by NEC or local electrical inspector.
6. 90° elbow.
7. UFER grounding installation in accordance with NEC.
8. Customer's service wire - 18" out of box.
9. 3" Schedule 40 PVC conduit, couplings and 36" minimum radius elbows.

▲ Items owned by CLPUD and installed by customer (Figures 19 & 20)

10. Pullstring.
11. Service hand-hole (HH-14 or HH-20) to be installed within 10' of the meter base.

□ Items owned and installed by CLPUD

(Figures 19 & 20)

12. Secondary hand-hole, or Pole.
13. Meter.
14. Service wire (inside conduit).

MANUFACTURED HOMES

If you are installing an underground service to your manufactured home, your service equipment can be installed in one of two ways:

1. On a customer-owned meter pedestal.
2. On the manufacturer installed home, if the following conditions are met:
 - The manufacturer installed the service equipment at the time your home was built.
 - Or the service equipment meets the meter base requirements listed below.

A meter base installed on manufactured homes must:

- Be located on an outside wall of your home.
- Be located on the front or within 4 feet of your home closest to normal public access.
- Be between 5 and 6 feet above finished grade, unless it is a pedestal (then 3' - 4' above finished grade).
- Not be in a walkway, breezeway or carport
- Not be in an area that is being fenced, or where decking or foliage will block easy access to it.
- Meet CLPUD's size requirements (see Figure 24).

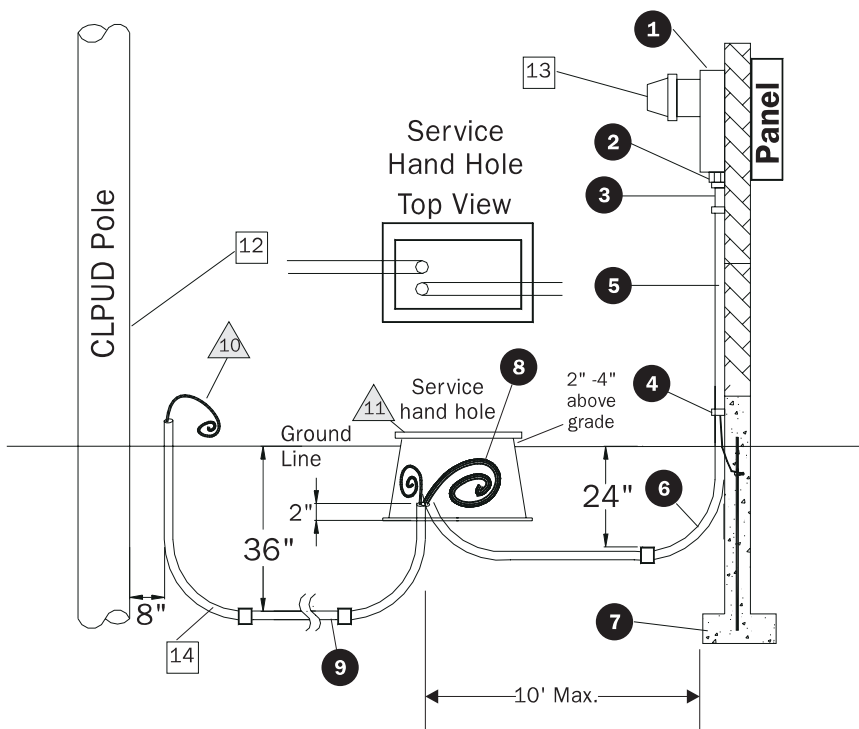

Figure 20.
Surface-mounted meter base with CLPUD pole.

METER PEDESTALS

A meter pedestal is a structure that supports your service equipment. If a meter pedestal is required for your project, it is your responsibility to purchase and install it.

The NEC requires that manufactured homes have a disconnect switch installed within 30 feet of the home on the side of the home facing normal public access. Normally, your meter base is installed at the same location.

You have two meter pedestal options:

1. **Custom built-** a pedestal that you or your electrical contractor builds. See Figure 21.
2. **Factory built-** a pedestal that you buy. See Figure 22.

Items owned and installed by customer (Figs. 21, 22)

1. 6 in. x 6 in. x 8 feet min. fully pressure treated post.
2. Service entrance equipment.
3. Service conduit as specified on page 14.
4. Ground wire (in accordance with NEC).
5. Ground Rods (in accordance with NEC; 2 required).
6. Customer conductors - 18" out of box.
7. Elbows, 2-90° PVC conduit with 24" min. radius.
8. Schedule 40 (minimum) PVC electric conduit.
9. Factory-built meter pedestal.
10. 3" Schedule 40 PVC conduit, couplings and 36" minimum radius elbows.

Items owned by CLPUD and installed by customer (Figs. 21, 22)

11. Pullstring.
12. Service Hand-hole (HH-14 or HH-20).

Items owned and installed by CLPUD (Figs. 21, 22)

13. Service line.
14. Meter.

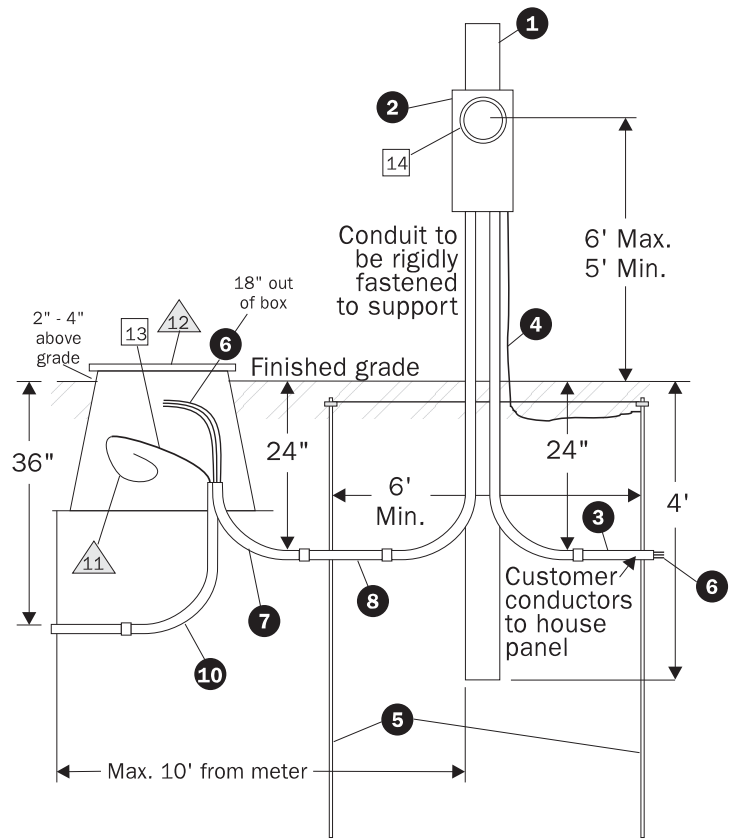

Figure 21.
Custom built meter post.

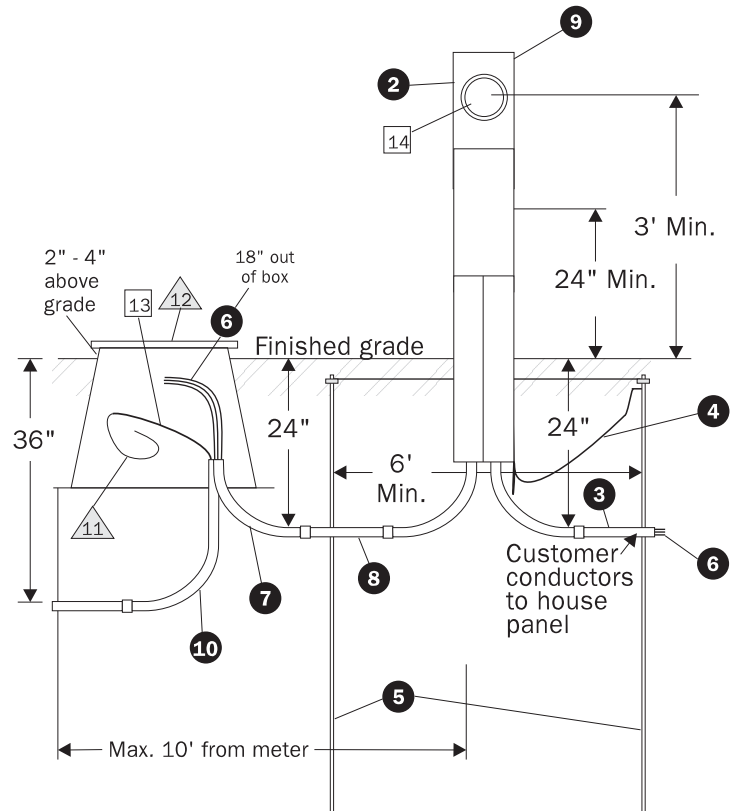

Figure 22.
Factory built meter pedestal.