



UNDERGROUND SERVICE

GENERAL REQUIREMENTS

The following is a checklist, which should be used as a guide to assist you in preparing your project for the installation of your underground service. Once you have completed these items, Central Lincoln will install your service line and meter.

- Ask us where your service line will originate. Call your nearest service office and ask to speak to an engineer (see SECTION A).
- Determine an acceptable location for your meter base (see SECTION A).
- Dig a trench and provide conduit from your meter base to the service hand-hole location, then to the location where your service will originate.
- Install Central Lincoln-provided service hand-hole (HH-14 or HH-20), and Central Lincoln provided pull string.
- Install your service equipment.
- Have the local electrical inspection agency (see SECTION A) approve your service installation.
- Call Central Lincoln's service office and notify them that you are inspected and have a "green tag" sticker on your meter base.

GETTING STARTED

The first step when installing a new underground service is to contact our nearest service office and ask an engineering technician where your service will originate.

Next, determine the location of your meter base. As stated previously, your meter base should be located outside and on the front, or within 4 feet of it on the side closest to normal public access (see Figure A-1).

When choosing your meter base location, be sure to consider the types of terrain where your conduit will be buried. You are required to provide, install and maintain conduit, and Central Lincoln is responsible for repairing service line if it ever fails. You must use 3" inch Schedule 40 PVC electrical grade conduit unless dictated by other ordinances and approved by Central Lincoln. You will also need a service hand-hole.

Customer-installed continuous conduit runs shall not contain more than three 90-degree elbows, or a maximum of 270 degrees of long radius bends, unless pre-approved by an engineering technician.

Conduit runs of more than 50 feet, or containing more than two 90 degree PVC elbows shall have a Central Lincoln-provided pullstring installed.

SERVICE EQUIPMENT INSTALLATION REQUIREMENTS

After you have determined the meter base location, the service line route, the size of the service you want (200 or 400 amp), you are ready to begin installing your service

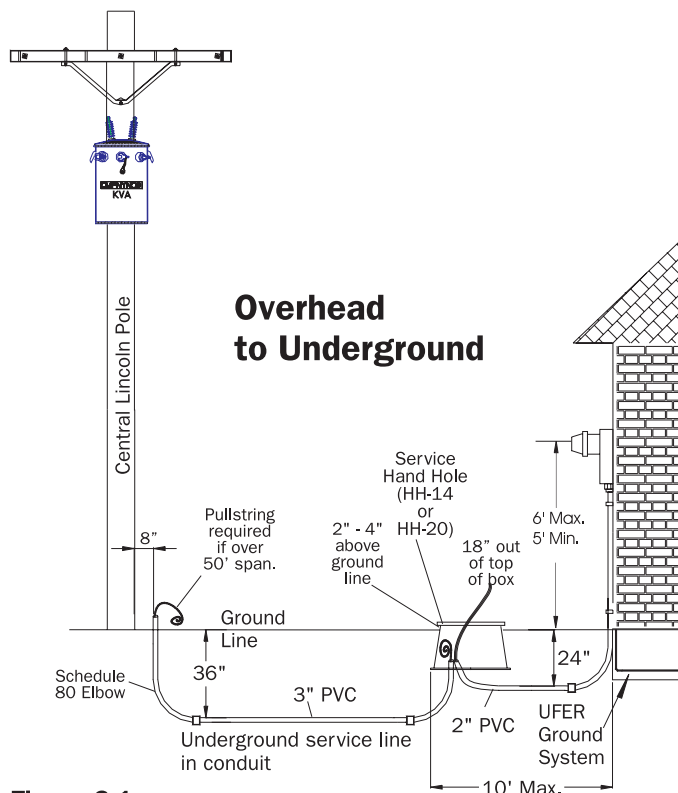

Figure C-1.
Typical overhead to underground service.

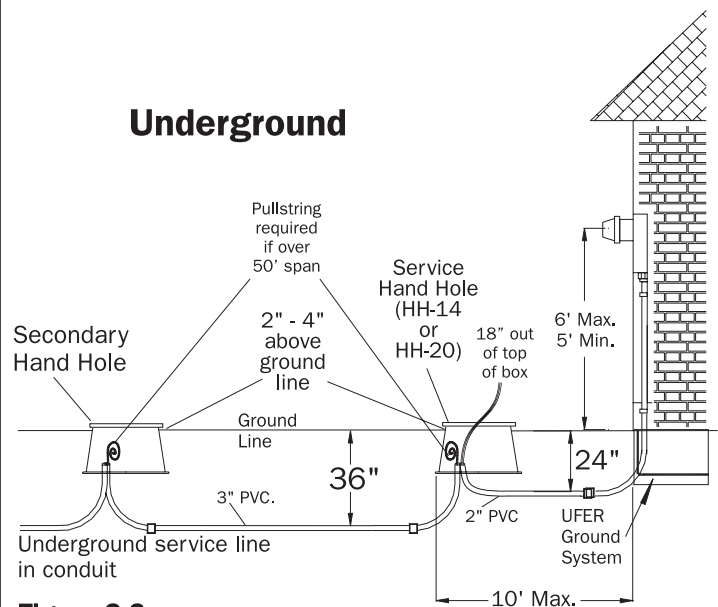

Figure C-2.
Typical underground service.

equipment.

There are three ways this equipment can be installed:

Flush mounted (see Figure C-4)

Surface mounted (see Figure C-5)

Pedestal mounted (see Figures C-6 & C-7)

When installing your service equipment, make sure that you install your meter base so that the center of the meter will be between 5 and 6 feet above finished grade.

TRENCHING REQUIREMENTS

You are to provide a trench, 24 inches deep, from your meter base to the service hand-hole (HH-14 or HH-20). Your trench will then continue, at 36 inches deep, to the pole, transformer, or secondary hand-hole where your service will originate. The trench must have a level, flat bottom, void of shifting soil. The trench must be free of all sharp rock and construction debris. There must be at least 12 inches of separation from all other utilities within the trench (see Figure C-3). The trench must be a minimum of 3 feet from sewer and gas, 5 feet from septic tanks and 10 feet from any drain fields.

When trenching to a transformer, or any energized structures, don't use any digging equipment other than a hand shovel within 5 feet of transformer. **NOTE: For underground service installations, don't dig or install any conduit or wire into an existing Central Lincoln vault without assistance from a qualified Central Lincoln employee. (Access to Central Lincoln equipment by persons other than Central Lincoln employees is prohibited.)** Remember, **do not dig under the transformer.**

Also remember:

Call before you dig: **811 (see SECTION A).**

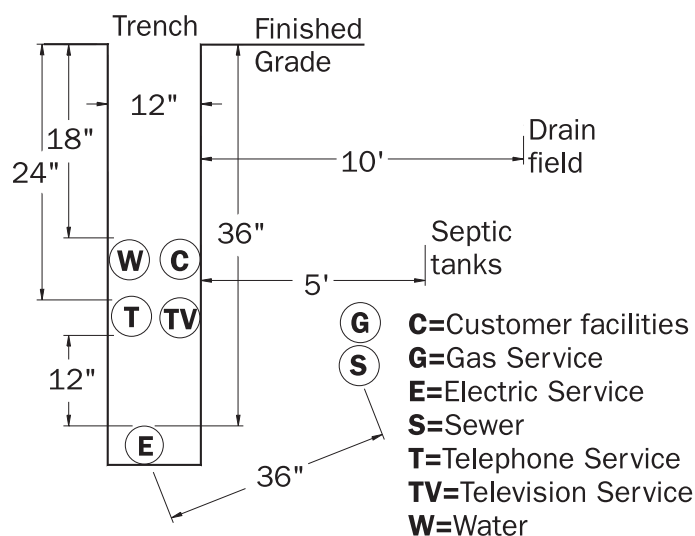

Figure C-3.
Service line trench detail.

CONDUIT

Customer will provide conduit and conduit elbows from the meter base to the service hand-hole (generally 2" - see NEC). Continue with a second set of 3" conduit and conduit elbows from the service hand-hole to the Central Lincoln source (pole, transformer or secondary hand-hole). The conduit will be Schedule 40 PVC electrical grade unless otherwise required by the engineering technician, road right-of-way administrator, or electrical inspector (see Figures C-1, C-2).

You are required to keep the conduit clean and clear of debris and water. End plugs will be provided by Central Lincoln, and you are required to have these installed.

Do not install conduit into energized equipment such as a transformer or an energized hand-hole.

At a transformer, or energized hand-hole location, you will need to call our service office to coordinate our being at the site to assist you in installing the elbow, pullstring and backfill.

You will need to install all conduit, pullstring, service hand-hole, trenching and backfill from the meter base to the Central Lincoln source (pole, transformer, secondary hand-hole).

SERVICE HAND-HOLE

You'll need to pick up and transport a service hand-hole from Central Lincoln to your site. (Ask engineering technician for details.) If your service is a 200 amp single meter base installation you can pick up the HH-14 at your local service office.

If you have a bigger meter base, or more than one meter, you'll need to pick up a larger service hand-hole from your local Central Lincoln warehouse. Ask your engineering technician for warehouse location and hours of service.

It is your responsibility to install the service hand-hole in your trench (see Figures C-1, C-2 & C-8), within 10 feet of the meter base. The lid portion of the service hand-hole must be above the finished grade.

Two conduit elbows are required inside the service hand-hole (one from the meter and one from the pole, transformer or secondary hand-hole). The two elbows are to be 2" above the bottom of the dirt floor of the hand-hole, and centered in the short side of the hand-hole (see the Top View in Figures C-4- C-5 & C-8).

Do not install the service hand-hole in a concrete area unless you receive prior instruction from an engineering technician. If the service hand-hole fills with water, you are required to provide adequate drainage, possibly excavating a larger area and underlying the service hand-hole with gravel.

Central Lincoln crews must have easy access to the hand-hole cover at all times. Hand-hole must not be covered with pavement, deck, landscaping, etc.

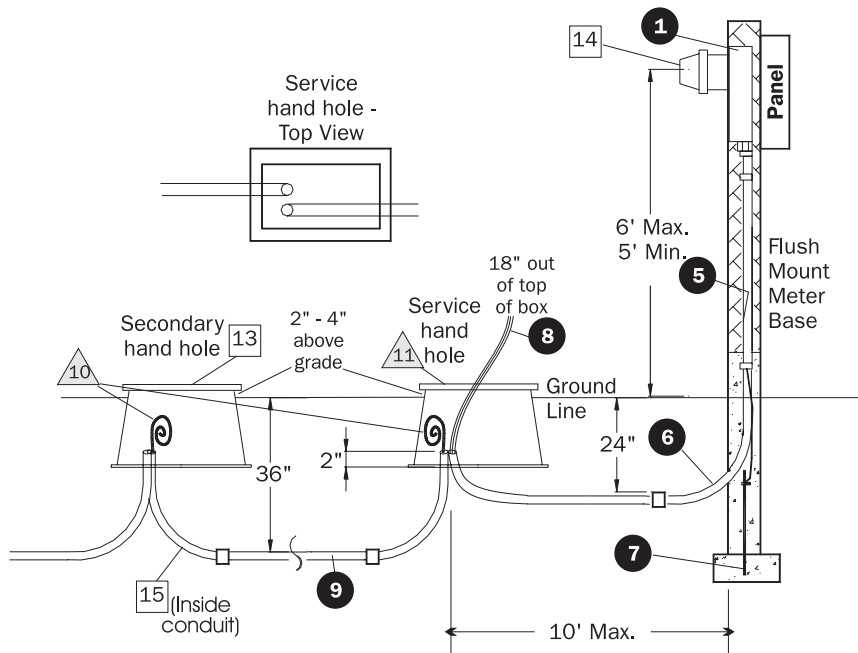

Figure C-4.
Flush-mounted meter base with Central Lincoln secondary hand hole.

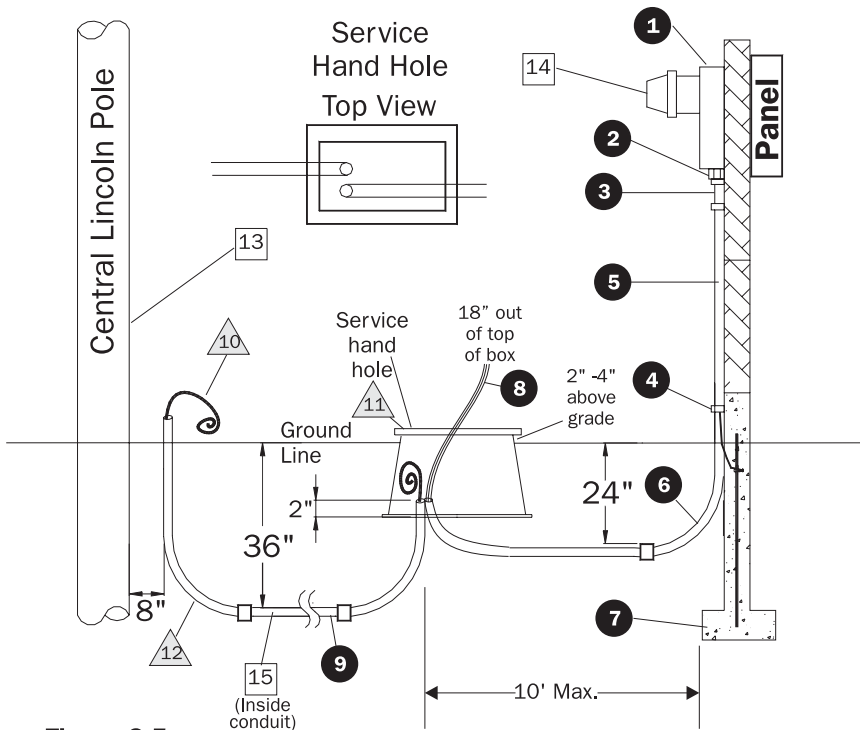

Figure C-5.
Surface-mounted meter base with Central Lincoln pole.

PULLSTRING

Pull string is to be blown in after the sections of the conduit have been glued and the glue has properly dried. Make sure the pull string does not get glued to the conduit. You will not be required to install pull string unless your trench is over 50 feet long, or has more than 180 degrees in elbows.

BACKFILL

After you have installed the trench, conduit, service hand-hole and pullstring, you're ready to call your service office for a trench inspection. You may use the original trench material for backfill, after the inspection, if it is clean (does not contain rock, construction debris, etc). Otherwise, sand is the preferred backfill.

FINAL INSPECTION

All Central Lincoln underground box and duct systems done by customers, contractors or builders will require a final inspection and approval by a Central Lincoln Operations Department inspector. The Central Lincoln inspector must approve all jobs requiring trenching before the Central Lincoln service or line crew can be dispatched to do the electrical installation.

● Items owned and installed by customer

(Figs. C-4 & C-5)

1. Meter base.
2. Insulating bushing and lock nut.
3. Terminal adapter.
4. Conduit strap.
5. Service entrance conduit as specified by NEC or local electrical inspector.
6. 90° elbow.
7. UFER grounding installation in accordance with NEC.
8. Customer's service wire - 18" out of top of box.
9. 3" Schedule 40 PVC conduit, couplings and 36" minimum radius elbows.

▲ Items owned by Central Lincoln and installed by customer (Figures C-4 & C-5)

10. Pullstring.
11. Service hand-hole (HH-14 or HH-20) to be installed within 10' of meter base.
12. 3" Schedule 80 PVC, 36" minimum radius elbow.

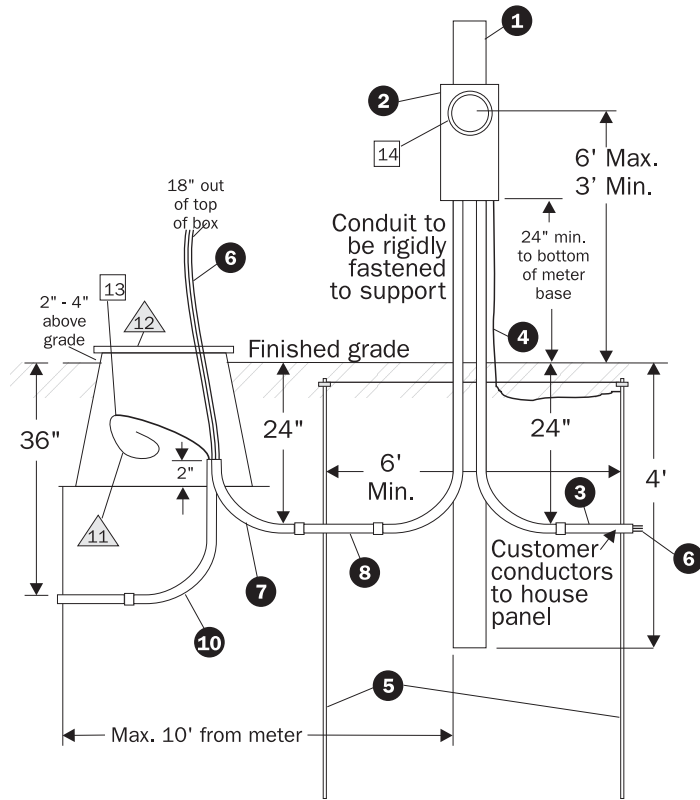

Figure C-6.
Custom built meter pedestal.

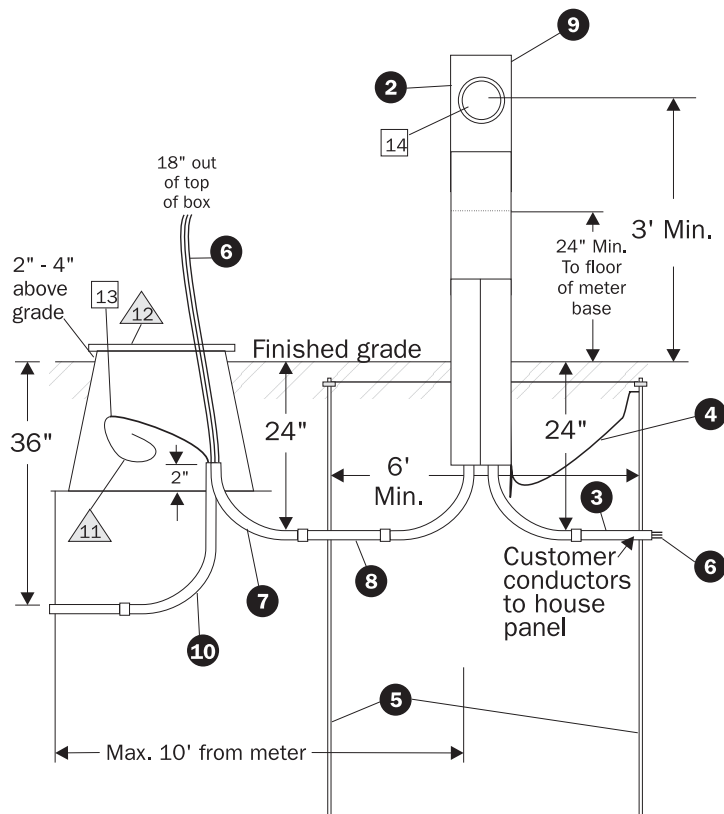

Figure C-7.
Factory built meter pedestal.

☐ **Items owned & installed by Central Lincoln** (Figures C-4 & C-5)

- 13. Secondary hand-hole, or pole.
- 14. Meter.
- 15. Service wire (inside conduit).

MANUFACTURED HOMES

If you are installing an underground service to your manufactured home, your service equipment can be installed in one of two ways:

1. On a customer-owned meter pedestal.
2. On the manufacturer installed home, if the following conditions are met:
 - Manufacturer installed the service equipment at time your home was built.
 - Or the service equipment meets the meter base requirements listed below.

A meter base installed on manufactured homes must:

- Be located on an outside wall of your home.
- Be located on the front or within 4 feet of your home closest to normal public access.
- Be between 5 and 6 feet above finished grade, unless it is a pedestal (then 3' - 4' above finished grade).
- Not be in a walkway, breezeway or carport
- Not be in an area that is being fenced, or where decking or foliage will block easy access to it.
- Meet Central Lincoln's size requirements (see SECTION D).

METER PEDESTALS

A meter pedestal is a structure that supports your service equipment. If a meter pedestal is required for your project, it is your responsibility to purchase and install it.

The NEC requires that manufactured homes have a disconnect switch installed within 30 feet of the home on the side of the home facing normal public access. Normally, your meter base is installed at the same location.

You have two meter pedestal options:

1. **Custom built**- a pedestal that you or your electrical contractor builds. See Figure C-6.
2. **Factory built**- a pedestal you buy. See Figure C-7.

● **Items owned and installed by customer** (Figs. C-6, C-7)

1. 6 in. x 6 in. x 8 feet min. fully pressure treated post.
2. Service entrance equipment.
3. Service conduit as specified.
4. Ground wire (in accordance with NEC).
5. Ground Rods (in accordance with NEC; 2 required).
6. Customer conductors - 18" out of box.
7. Elbows, 2-90° PVC conduit with 24" min. radius.

8. Schedule 40 (minimum) PVC electric conduit.
9. Factory-built meter pedestal.
10. 3" Schedule 40 PVC conduit, couplings and 36" minimum radius elbows.

△ Items owned by Central Lincoln & installed by customer

(Figs. C-6 & C-7)

11. Pullstring.
12. Service Hand-hole (HH-14 or HH-20).

□ Items owned and installed by Central Lincoln (Figs. C-6 & C-7)

13. Service line.
14. Meter.

EXISTING DIRECT-BURIED UNDERGROUND

In the past, some underground service lines were direct-buried in the ground, rather than placed in conduit. These old systems are prone to periodic failures, which is why we no longer allow this type of installation.

However, Central Lincoln will find and repair damage to your existing direct-buried underground service, and we will continue to do so as necessary at no cost to the customer. These direct-buried failures cause outages that are frustrating for the customer and expensive for Central Lincoln to repair, so we encourage customers with direct-buried service to upgrade to conduit-based systems.

Normally, a customer installing new underground service must provide all the conduit necessary for the installation. But as an incentive to upgrade, Central Lincoln will provide the necessary wire, conduit, 90 degree ells, HH-14 hand-hole, and pull string from our point of service to the hand-hole near your existing meter base. The customer is still required to provide any trenching necessary.

If you're interested in upgrading from a direct-buried system, please contact Central Lincoln before doing any of the work. A Customer Engineering Representative will meet with you to determine the proper route for any conduit installation before you dig. And an inspection is necessary of all conduit and substructure installation before trenches are back-filled.

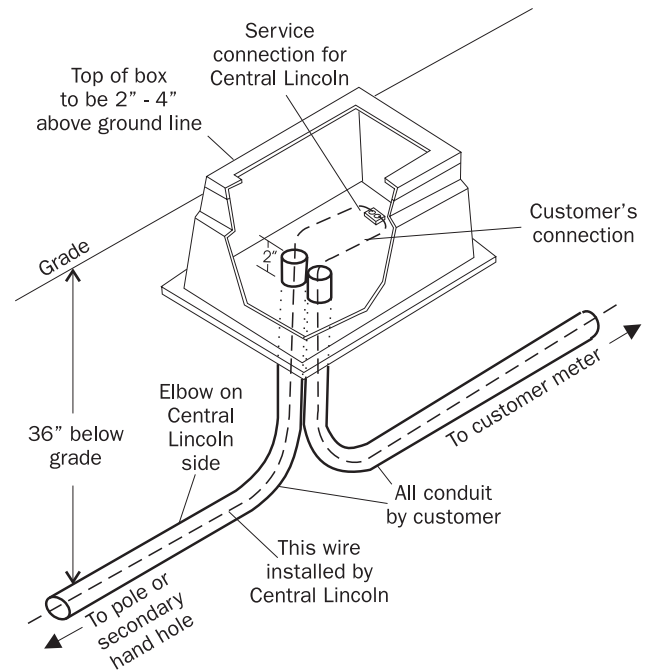

Figure C-8.
Installation of service hand hole (HH-14 or HH-20)