

TEMPORARY SERVICES



Where poles with transformers are adjacent to or near your project, you should request temporary overhead service (see Figure B-1). If the electrical facilities in your area are underground, you will need to install a temporary underground meter pedestal to obtain temporary power. If there is power in your area but the power lines are not visible, it is likely to be underground. Refer to SECTION C for more information on underground service.

The process and cost of obtaining your temporary overhead service can vary depending upon the location of our existing facilities. The least complicated and cheapest way a service can be installed is if a transformer is located on a pole on or along your property.

If you are in an overhead area, but will have a permanent underground meter base and you want to install the conduit and trench now, refer to SECTION C. In this case your temporary underground meter base must be installed within two feet of the service hand-hole.

If you are in an underground area, you must have an underground temporary service (see Figures B-3 and B-4).

Other installations are more complicated. All installations are reviewed by Central Lincoln. Please speak with one of our engineering technicians if you have any questions.

There is a **processing fee** to connect a temporary service. If any engineering is required, additional costs may be incurred.

OVERHEAD METER LOCATION

Your temporary meter post should be located on your property. Install the meter post as close as 6' (preferred) to the Central Lincoln pole, but no more than 100' from the pole that will serve you. The reason for this limitation is ensuring that your temporary service pole can withstand the weight of the conductor. If a distance greater than 100' is required, please contact your local service office and ask an engineering technician for approval prior to construction. A taller, stouter post with additional bracing could be required.

In addition to the distance limitation mentioned above, please consider the following:

- The path that the service will take should not cross property belonging to other individuals.
- If the service line will pass through trees or brush, a three foot path must be cleared and maintained to allow our service personnel to access the

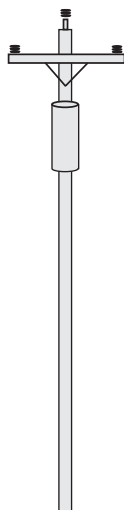

Figure B-1.
Pole with transformer.

line, and to allow the lines to hang without contacting trees or limbs. Maintaining this clear path is your responsibility.

- The service line path should avoid areas where vehicular traffic will occur, unless your temporary post height is increased to provide adequate clearance. See SECTION E for service line clearance requirements.
- Meters should face the road or driveway to facilitate drive-by readings.

If you have any questions, please contact us.

OVERHEAD CLEARANCE REQUIREMENTS

The National Electrical Code (NEC) and the National Electrical Safety Code (NESC) have established minimum clearance requirements to maintain safe height distance for electrical conductors over various terrain.

The NEC and NESC require the lowest point of a service conductor to be at least 12 feet 6 inches above the ground. The bottom of the drip loop must be a minimum of 10 feet 6 inches above the ground (see Figure B-2). **NOTE: Clearance over any driveway must be at least 18 feet.**

Figure E-2 shows the clearance requirements for the types of terrain most commonly encountered. These clearances apply to both permanent and temporary weatherheads.

It is not your responsibility to provide and install the conductor, but you are required to provide a point of attachment at your service post that will allow Central Lincoln to meet the clearance requirements.

If you need further detail, please consult the current issue of the NEC or contact the local electrical inspection agency (see SECTION A).

OVERHEAD SERVICE INSTALLATION

The following items must be completed before we can energize your service:

- Contact a Central Lincoln representative and request a temporary service.
- The engineer will call for an appointment at the site.
- Obtain an electrical work permit from the electric inspection agency (see SECTION A).
- Install a meter post and meter base.
- Obtain an electrical inspection ("green tag").
- After these items are completed, call our service office. Inform our representative that your installation has been inspected and passed, and state that

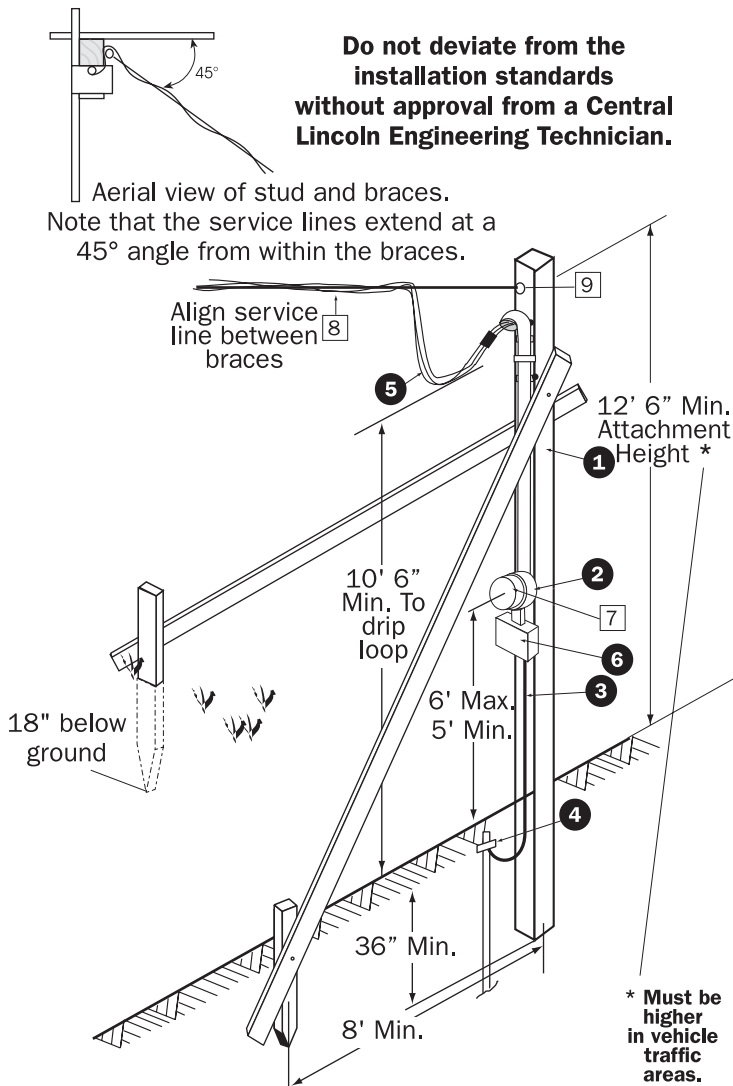

Figure B-2.
Temporary overhead service installation.

you're ready for temporary service.

Figure B-2 is a drawing of the standard temporary overhead service installation recommended by Central Lincoln. The specifications given are the minimum acceptable.

● Items owned & installed by the customer (Figure B-2)

1. A 6" x 6" x 16' minimum, continuous, single structure, pressure treated, firmly set and drilled with an 11/16" hole 6" below top of pole in line with service drop.
2. Meter base with ground wire from the meter base to service neutral and an electrical permit ("green tag") attached.
3. Ground wire (per NEC) with ground wire connected to the meter base or switchbox lug and grounded to ground rod with approved cast clamp.
4. Ground rod (per NEC) 8' long.
5. Service entrance conductors (18" out of weatherhead for connection drops).
6. Switch Box with polarized receptacle for 240 V., 1 phase motors with grounding terminal. It must be a receptacle with grounding terminal that is connected to

an approved grounding electrode (service conductor is not approved grounding).

□ Items owned & installed by Central Lincoln (Figure B-2)

7. Meter.
8. Service Line.
9. Insulated clevis. (Minimum attachment height of 12' 6" may increase to meet clearance requirements above roads, driveways, etc. Consult your Central Lincoln engineer.)

UNDERGROUND METER BASE LOCATION

The following items are required to properly locate your meter pedestal:

- Set the meter pedestal on your property.
- Install the meter pedestal at the Central Lincoln approved meter location. You will need confirmation from a Central Lincoln engineering technician.
- Face meter base to vehicular traffic.

UNDERGROUND SERVICE INSTALLATION

The following items must be completed prior to energizing your service:

- Contact a Central Lincoln representative and request a temporary service.
- An engineer will call you to arrange an appointment at the site.
- Obtain an electrical work permit from the inspection agency (see SECTION A).
- Obtain underground locates (**811**).
- Install a meter post and meter base in the appropriate location.
- Provide the appropriately sized conductor from your meter base to Central Lincoln's connection point. Please leave 5 feet of extra wire at a hand-hole or locator pin, and 10 feet at a transformer pad. Consult the NEC for the appropriate wire sizes.
- Obtain a "green tag".
- Cover your wire except where our personnel will be installing and connecting your wire to ours.
- After these items are completed, call our service office and inform a representative that your installation has been inspected.

UNDERGROUND METER BASE REQUIREMENTS

It is your responsibility to provide a buried cable from your meter base to our transformer or hand-hole.

The requirements to connect to an overhead converted to underground meter pedestal are shown in Figure B-3. The cable you install should be sized per the NEC and should have a minimum cover of 24".

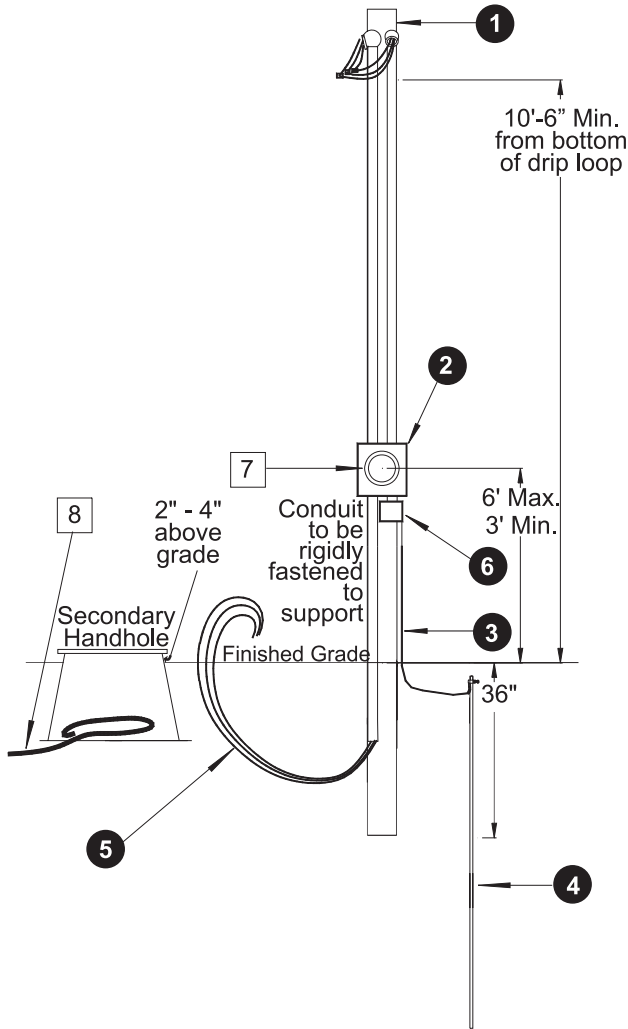

Figure B-3.
Trenching requirements for an overhead pedestal converted to underground pedestal.

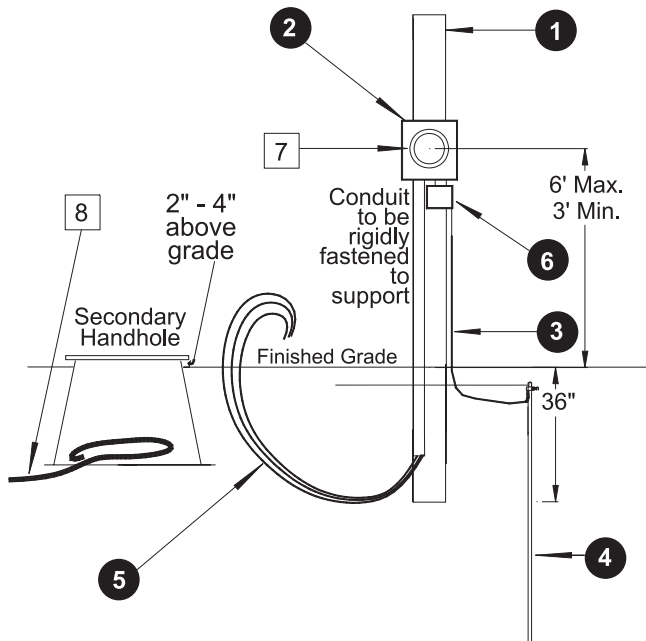

Figure B-4.
Temporary underground service installation.

If our connection point is a hand-hole or transformer, trench to our nearest service location and leave your wires exposed. If you discover any other conductors while digging your trench, please leave them covered. Remember, **do not install conduit or elbows inside the transformer or transformer substructure** without Central Lincoln direct supervision and assistance.

REMINDER: You are required to call the “One Call” system (811) and request buried utility locations **at least 2 business days before digging**. Any trenching within 24” of existing underground facilities must be done by hand.

Figure B-4 illustrates an underground temporary meter pedestal installation. Please note the dimensions shown. Deviations from these recommended standards could result in a delay in receiving your service and/or your service being denied. Please contact us if you have any questions.

● Items owned/installed by the customer (Figs. B-3, B-4)

1. A 6" x 6", continuous, single structure, firmly set.
2. Meter base with ground wire from the meter base to service neutral and an electrical permit (“green tag”).
3. Ground wire (per NEC) with ground wire connected to the meter base or switchbox lug and grounded to ground rod with approved cast clamp.
4. Ground rod (per NEC) 8’ long.
5. Service wire - enough to reach the base of the Central Lincoln ground structure, plus 5’ of wire to make connections.
6. Switch Box with polarized receptacle for 240 V., 1-phase motors, with grounding terminal. It must be a receptacle with grounding terminal that is connected to an approved grounding electrode (service conductor is not approved grounding).

□ Items owned & installed by Central Lincoln (Figs. B-3, B-4)

7. Meter
8. Service Line